

FEATURES

- HIGH K DIELECTRIC
- HIGH CAPACITANCE DENSITY
- EXCELLENT MECHANICAL STRENGTH
- NICKEL BARRIER TERMINATIONS

RoHS Compliant

Includes all homogeneous materials

*See Part Number System for Details

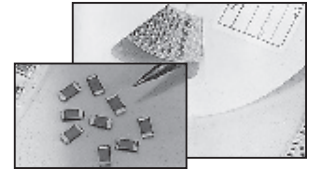

SPECIFICATIONS

Capacitance Range	0.01 μ F ~ 0.82 μ F (see high CV datasheet for higher capacitance values)
Capacitance Tolerance	+80%/-20% (Z)
Operating Temperature Range	-30°C ~ +85°C
Temperature Characteristics	+22%, -82% max. capacitance Δ over temperature range
Rated Voltages	4Vdc, 6.3Vdc, 16Vdc, 25Vdc, 50Vdc & 100Vdc (see NMC-H Series for higher voltages)
Dissipation Factor	(See Values Table)
Insulation Resistance	10,000Megohms min. or 500Megohm/ μ F min. whichever is less @ +25°C
Dielectric Withstanding Voltage	150% of Rated Voltage for 1 ~ 5 seconds, 50mA maximum current
Test Conditions (EIA-198-2E)	1KHz, 1.0V \pm 0.2Vrms

Note: Reflow soldering allowed for all case sizes. Contact NIC for wave soldering restrictions.

Typical Y5V C and DF Change over Temp.

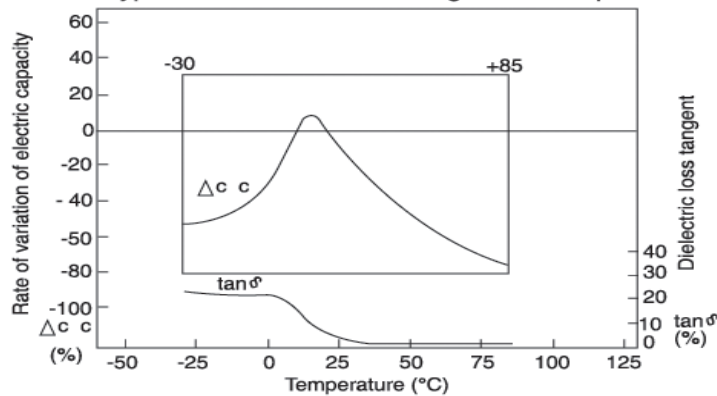

CAPACITANCE CHANGE AS FUNCTION OF APPLIED VOLTAGE (VDC)

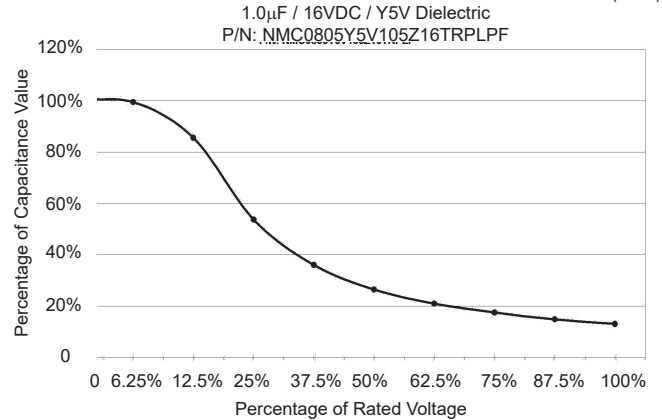

PART NUMBER SYSTEM

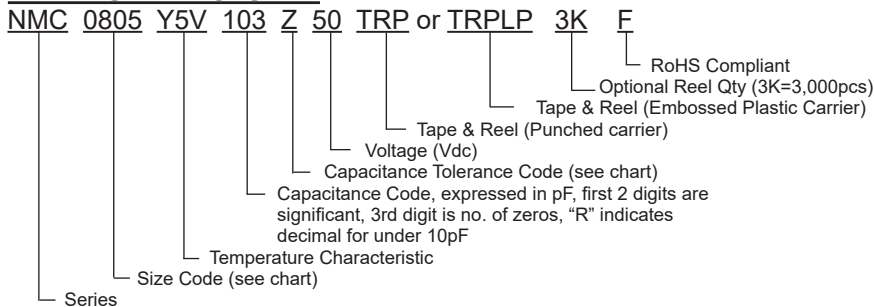

Y5V CAPACITOR SIZE AND DISSIPATION FACTOR CHART (mm)

EIA Case Size	0201			0402				0603				
Length (L)	0.6 ± 0.05			1.0 ± 0.05				1.6 ± 0.15				
Width (W)	0.3 ± 0.05			0.5 ± 0.05				0.8 ± 0.15				
Thickness max. (T)	0.33			0.6				1.0				
Termination Width (P)	0.10 ~ 0.20			0.2±0.1				0.12 ~ 0.51				
Capacitance	Working Voltage (Vdc)											
	4	6.3	10	6.3	10	16	25	50	10	16	25	50
0.01µF					12.5%	9%	7%	7%	12.5%	7%	5%	5%
0.015µF					12.5%	9%	7%	7%	12.5%	7%	5%	5%
0.022µF	16%	16%	12.5%	16%	12.5%	9%	7%	7%	12.5%	7%	5%	5%
0.027µF	16%	16%	12.5%	16%	12.5%	9%	7%	7%	12.5%	7%	5%	5%
0.033µF	16%	16%	12.5%	16%	12.5%	9%	7%	7%	12.5%	7%	5%	5%
0.036µF	16%	16%	12.5%	16%	12.5%	9%	7%		12.5%	7%	5%	5%
0.039µF	16%	16%	12.5%	16%	12.5%	9%	7%		12.5%	7%	5%	5%
0.047µF	16%	16%	12.5%	16%	12.5%	9%	7%		12.5%	7%	5%	5%
0.056µF	16%	16%		16%	12.5%	9%			12.5%	7%	5%	5%
0.068µF	16%	16%		16%	12.5%	9%			12.5%	7%	5%	5%
0.075µF	16%	16%		16%	12.5%	9%			12.5%	7%	5%	5%
0.082µF	16%	16%		16%	12.5%	9%			12.5%	7%	5%	5%
0.1µF				16%	12.5%	9%			12.5%	7%	7%	7%
0.15µF				16%	12.5%				12.5%	9%	9%	9%
0.18µF				16%	12.5%				12.5%	9%	9%	9%
0.22µF				16%	12.5%				12.5%	9%	9%	9%
0.27µF				16%	12.5%				12.5%	12.5%	9%	
0.33µF				16%	12.5%				12.5%	12.5%	9%	
0.36µF				16%	12.5%				12.5%	12.5%	9%	
0.39µF				16%	12.5%				12.5%	12.5%	9%	
0.47µF				16%	12.5%				12.5%	12.5%	9%	
0.56µF				16%					12.5%	12.5%	9%	
0.68µF				16%					12.5%	12.5%	9%	
0.82µF				16%					12.5%	12.5%	9%	

(CONSULT FACTORY FOR CAPACITANCE VALUES NOT LISTED)

Percentages in the table represent the dissipation factor for that value.

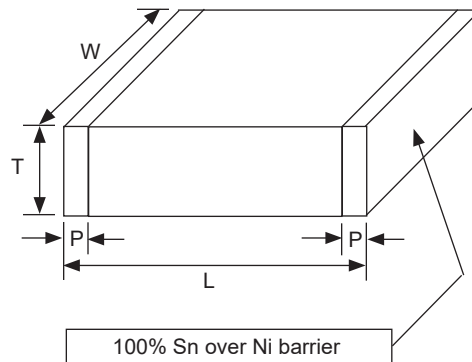

See NMC High CV series for values above 0.82µF

Y5V CAPACITOR SIZE AND DISSIPATION FACTOR CHART (mm)

EIA Case Size	0805						1206					
Length (L)	2.0 ± 0.2						3.2 ± 0.2					
Width (W)	1.25 ± 0.2						1.6 ± 0.2					
Thickness max. (T)	1.30						1.80					
Termination Width (P)	0.25 ~ 0.71						0.25 ~ 0.71					
Capacitance	Working Voltage (Vdc)											
	6.3	10	16	25	50	100	6.3	10	16	25	50	100
0.01µF	16%	12.5%	9%	5%	5%	5%	16%	12.5%	9%	5%	5%	5%
0.015µF	16%	12.5%	9%	5%	5%	5%	16%	12.5%	9%	5%	5%	5%
0.022µF	16%	12.5%	9%	5%	5%	5%	16%	12.5%	9%	5%	5%	5%
0.027µF	16%	12.5%	9%	5%	5%	5%	16%	12.5%	9%	5%	5%	5%
0.033µF	16%	12.5%	9%	5%	5%	5%	16%	12.5%	9%	5%	5%	5%
0.036µF	16%	12.5%	9%	5%	5%	5%	16%	12.5%	9%	5%	5%	5%
0.039µF	16%	12.5%	9%	5%	5%	5%	16%	12.5%	9%	5%	5%	5%
0.047µF	16%	12.5%	9%	5%	5%	5%	16%	12.5%	9%	5%	5%	5%
0.056µF	16%	12.5%	9%	5%	5%	5%	16%	12.5%	9%	5%	5%	5%
0.068µF	16%	12.5%	9%	5%	5%	5%	16%	12.5%	9%	5%	5%	5%
0.075µF	16%	12.5%	9%	5%	5%	5%	16%	12.5%	9%	5%	5%	5%
0.082µF	16%	12.5%	9%	5%	5%	5%	16%	12.5%	9%	5%	5%	5%
0.1µF	16%	12.5%	9%	5%	5%	5%	16%	12.5%	9%	5%	5%	5%
0.15µF	16%	12.5%	9%	5%	5%	5%	16%	12.5%	9%	5%	5%	5%
0.18µF	16%	12.5%	9%	5%	5%	5%	16%	12.5%	9%	5%	5%	5%
0.22µF	16%	12.5%	9%	5%	5%	5%	16%	12.5%	9%	5%	5%	5%
0.27µF	16%	12.5%	9%	5%	5%	5%	16%	12.5%	9%	5%	5%	5%
0.33µF	16%	12.5%	9%	7%	7%	7%	16%	12.5%	9%	5%	5%	5%
0.36µF	16%	12.5%	9%	9%	9%	9%	16%	12.5%	9%	5%	5%	5%
0.39µF	16%	12.5%	9%	9%	9%	9%	16%	12.5%	9%	5%	5%	5%
0.47µF	16%	12.5%	9%	9%	9%	9%	16%	12.5%	9%	5%	5%	5%
0.56µF	16%	12.5%	9%	9%	9%	9%	16%	12.5%	9%	5%	5%	5%
0.68µF	16%	12.5%	9%	9%*	9%*	9%*	16%	12.5%	9%	5%	5%	5%
0.82µF	16%	12.5%	9%	9%*	9%*	9%*	16%	12.5%	9%	5%	5%	5%

*1.35mm maximum thickness

(CONSULT FACTORY FOR CAPACITANCE VALUES NOT LISTED)

Percentages in the table represent the dissipation factor for that value.

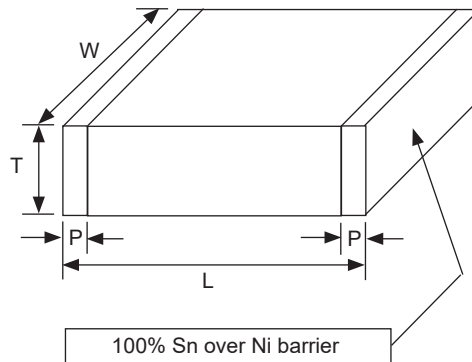

See NMC High CV series for values above 0.82µF

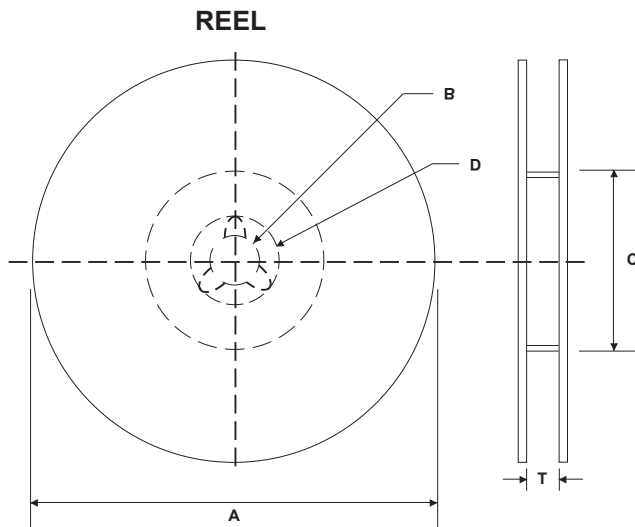

REEL DIMENSIONS (mm)

Reel Diameter (A)	B	C	D	T max.
7" (178 ± 2.0)	13 ± 0.5	50 min.	21 ± 1.0	8.4 +1.0/-0 (1812 case size 12.4 +2.0/-0)
10" (250 ± 2.0)		100 ± 1.0		
13" (330 ± 2.0)		100 ± 1.0		

7 INCH REEL QUANTITIES*

Size	01005	0201	0402	0603	0805	1206	1210	1812
Tape Size	8mm	8mm	8mm	8mm	8mm	8mm	8mm	12mm
Min. Qty Per Reel	20,000	15,000	10,000	4,000	4,000	4,000	2,000	1,000
Max. Qty Per Reel	20,000	15,000	10,000	4,000	5,000	5,000	5,000	2,000

*Quantity dependent on chip thickness. Contact NIC for reel quantities on larger diameter reels.

CARRIER TAPE MATERIAL

Parts with a thickness of $\geq 1\text{mm}$ will be taped on embossed plastic carrier. Parts with a thickness of less than 1mm will be taped on paper carrier

EMBOSSED PLASTIC CARRIER TAPE DIMENSIONS (mm)

Tape Size	W	F	E	P ₀	P ₂	D	K max.	T max.	P
8mm	8.0 ± 0.2	3.5 ± 0.05	1.75 ± 0.10	4.0 ± 0.1	2.0 ± 0.5	1.5 ^{+0.1} _{-0.0}	3.0	2.0	4.0 ± 0.1
12mm	12 ± 0.2	5.5 ± 0.05						4.5	8.0 ± 0.1

Notes:

- Specifications are in compliance with EIA RS481-1-A "Taping of Surface Mount Components for Automatic Placement"
- Dimensions A₀ (max.) equals component width dimension plus 0.5mm
- Dimension B₀ (max.) equals component length dimension plus 0.5mm

EMBOSSED PLASTIC CARRIER TAPE

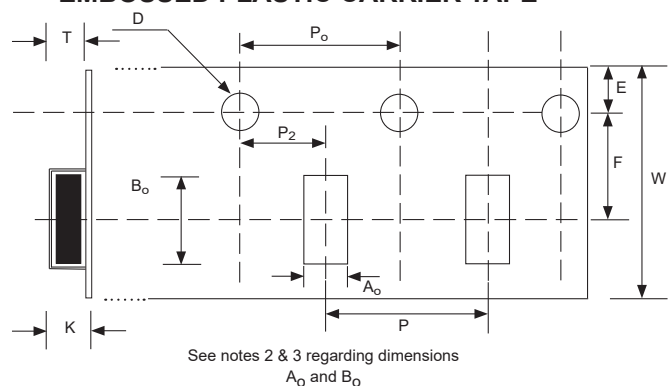

PUNCHED CARRIER TAPE DIMENSIONS (mm)

Type	A ₀	B ₀	W	F	E	P1	P0	D0	T1 max.	T2 max.	Mounting Hole
01005	0.25 ± 0.04	0.45 ± 0.04	8.0 ± 0.3	3.5 ± 0.05	1.75 ± 0.1	2.0 ± 0.05	4.0 ± 0.1	1.5 ^{+0.1} _{-0.0}	0.27	0.36	Angular Punch Hole
0201	0.37 ± 0.03	0.67 ± 0.05							0.45	0.80	
0402	0.65 ± 0.05	1.15 ± 0.05				4.0 ± 0.10			1.1	1.4	
0603	1.1 ± 0.2	1.9 ± 0.2									
0805	1.65 ± 0.2	2.4 ± 0.2									
1206	2.0 ± 0.2	3.6 ± 0.2									

PUNCHED CARRIER TAPE

