

NTRN Series

Aluminum Nitride High Precision Thin Film Chip Resistor



FEATURES

- ALUMINUM NITRIDE THIN FILM RESISTOR
- 50Ω ~ 30.1KΩ RESISTANCE RANGE
- RESISTOR TOLERANCES DOWN TO ±0.1%
- LOW TCR OPTIONS DOWN TO ±25 PPM/°C
- HIGH THERMAL CONDUCTIVITY
- POWER RATINGS TO 6.0W



SPECIFICATIONS

Type	EIA Size	Power Rating At 70°C	Temperature Range	Max.*1 Working Voltage	Max.*2 Overload Voltage	Resistance Tolerance (Code)	Temperature Coefficient (ppm/°C)	Resistance Range (Ω)
NTRN06	0603	0.5W	-55 °C ~ +155 °C	75V	150V	±0.1% (B) ±0.25% (C) ±0.5% (D) ±1% (F)	±25(C) ±50(D)	50Ω ~ 30.1KΩ
NTRN10	0805	1.0W		100V	200V			50Ω ~ 30.1KΩ
NTRN12	1206	2.0W		100V	200V			50Ω ~ 30.1KΩ
NTRN25	2512	6.0W		100V	200V			50Ω ~ 30.1KΩ

*Please refer to page 3 for information regarding max working and overload voltage ratings

DIMENSIONS (mm) & LAND PATTERNS (mm)

Type	L	W	H	T	t	A	B	C
NTRN06	1.55±0.10	0.80±0.10	0.43±0.15	0.30±0.15	0.50±0.20	0.37	0.99	0.86 ±0.10
NTRN10	2.00±0.15	1.25±0.15	0.43±0.15	0.35±0.15	0.60±0.20	0.50	1.08	1.32 ±0.10
NTRN12	3.05±0.20	1.55±0.20	0.43±0.15	0.50±0.15	1.20±0.20	0.60	1.90	1.80 ±0.10
NTRN25	6.30±0.20	3.10±0.20	0.43±0.15	0.70±0.25	1.60±0.25	2.77	2.31	3.20 ±0.20

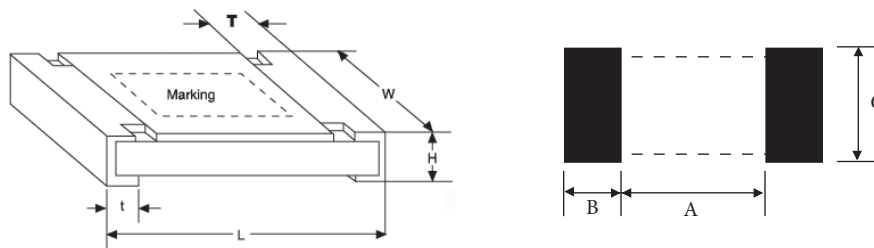

PART NUMBER SYSTEM

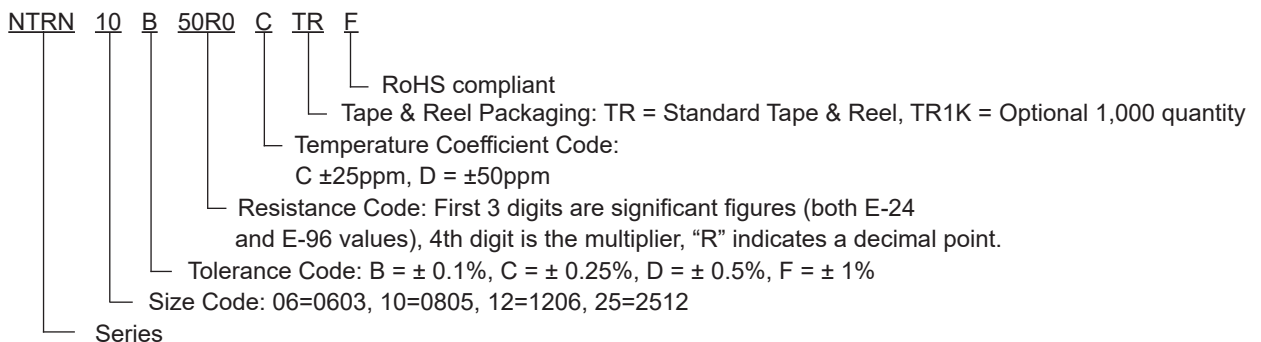

NTRN Series

Aluminum Nitride High Precision Thin Film Chip Resistor



Power Derating Curve: For operation above 70°C, power rating must be derated according to the following chart:

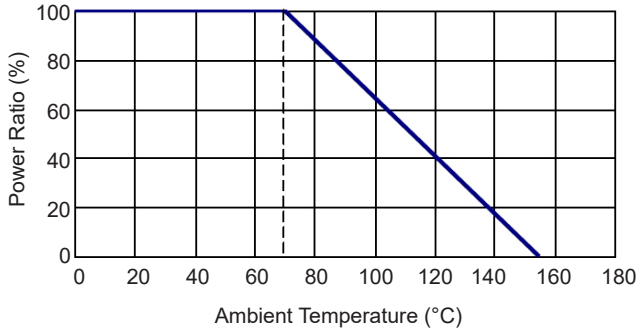

RCWV (Rated Continuous Working Voltage) = $\sqrt{P \cdot R}$ or Max. Operating voltage whichever is lower

Note *1 - Maximum allowable continuous Working Voltage for all resistors is the lower of the two values:

"Maximum Working Voltage" as specified above or:
 $\sqrt{\text{Power rating (Watts)} \times \text{Resistance (Ohms)}}$

Note *2 - Maximum Overload Voltage for all resistors is the lower of the two values:

Maximum Overload Voltage" as specified above or
 $2 \times \sqrt{\text{Power rating (Watts)} \times \text{Resistance (Ohms)}}$

SOLDERING CONDITIONS (IPC/JEDEC J-STD-020)

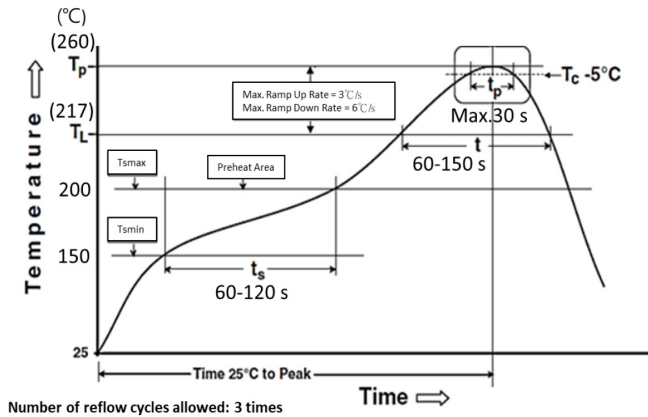

Pb-Free Assembly	Time
Preheat Temp min (Tsmin)	150°C
Preheat Temp max (Tsmax)	200°C
Preheat time (ts)	60 - 120 seconds
Ramp-up rate (TL to TP)	3°C/second max.
Liquidous temperature (TL)	217°C
Time (tL) maintained above TL	60 - 150 seconds
Peak Temperature min (TP min)	235°C
Peak Temperature max (TP max)	260°C
Time (TP) within 5°C of the specified classification temperature (Tc)	30 seconds max.
Ramp-down rate (TP to TL)	6°C/second max.
Time 25°C to peak temperature	8 minutes max.

STORAGE CONDITIONS

Storage Temperature: 15 ~28 °C; Humidity < 80%RH

NTRN Series

Aluminum Nitride High Precision Thin Film Chip Resistor



ENVIRONMENTAL CHARACTERISTICS

Item	Requirement	Test Method*
Temperature Coefficient of Resistance	As specified	MIL-STD 202 Method 304 +25/55/+25/+125/+25°C
Short Time Overload	$\Delta R \pm 0.5\%$	Actual power handling capability is limited by the end user mounting process. As with any high power chip resistor the ability to remove the heat is critical to the overall performance of the device
Insulation Resistance	> 9999M Ω	MIL-STD 202 Method 302 Apply 100VDC for 1 minute
Endurance	$\Delta R \pm 1.0\%$	MIL-STD-202 Method 108 70°C \pm 2°C, RCWV for 1000hrs with 1.5 hrs "ON" and 0.5 hrs "OFF"
Damp Heat with Load	$\Delta R \pm 0.4\%$	MIL-STD 202 Method 1 03 40 \pm 2°C, 90~95% R.H. RCWV for 1000 hrs with 1.5 hrs "ON" and 0.5 hrs "OFF"
Solderability	95% Minimum Coverage	MIL-STD 202 Method 208 245 \pm 5°C for 3 seconds
Resistance to Soldering Heat	$\Delta R \pm 0.2\%$	MIL-STD 202 Method 210 260 \pm 5°C for 10 seconds
Low Temperature Operation	$\Delta R \pm 0.2\%$	JISC 5201 1 4.36 1 hour, -65°C, followed by 45 minutes of RCWV
High Temperature Operation	$\Delta R \pm 0.2\%$	MIL-STD-202 Method 108 @ +155°C for 1000 hrs
Thermal Shock	$\Delta R \pm 0.2\%$	MIL-STD-202 Method 107 -55°C ~150°C, 100 cycles

PERFORMANCE CHARACTERISTICS

NTRN06 Chip Temperature vs. Applied Power

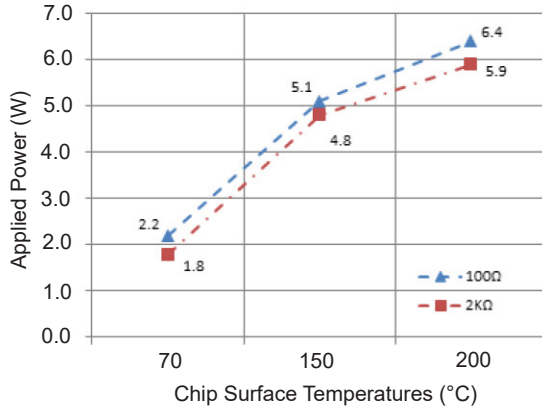

NTRN10 Chip Temperature vs. Applied Power

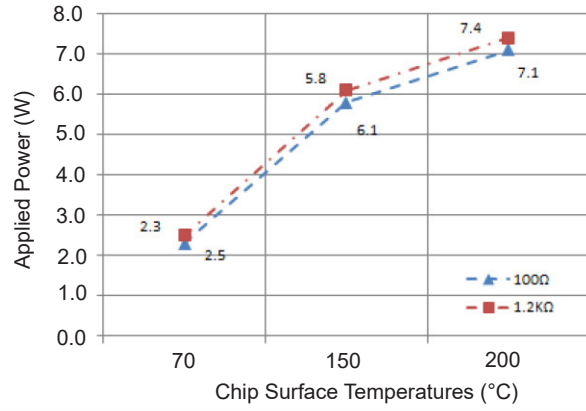

NTRN12 Chip Temperature vs. Applied Power

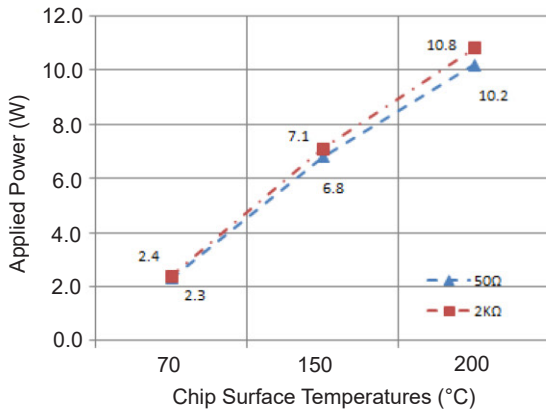

NTRN25 Chip Temperature vs. Applied Power

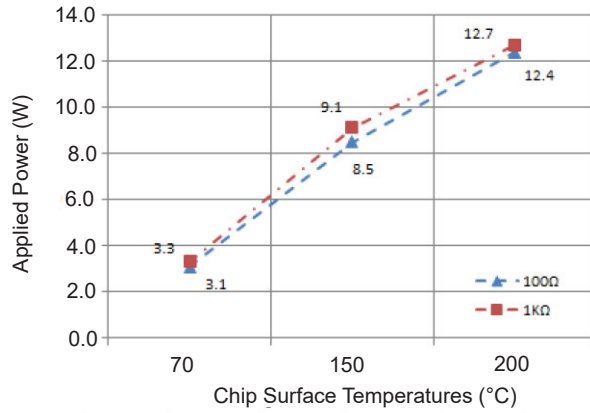



STANDARD E-24 AND E-96 VALUES AND RESISTANCE CODES

E-24		E-96							
Value & Code	Value	Code	Value	Code	Value	Code	Value	Code	
10	100	01	102	02	105	03	107	04	
11	110	05	113	06	115	07	118	08	
12	121	09	124	10	127	11	130	12	
13	133	13	137	14	140	15	143	16	
15	147	17	150	18	154	19	158	20	
16	162	21	165	22	169	23	174	24	
18	178	25	182	26	187	27	191	28	
20	196	29	200	30	205	31	210	32	
22	215	33	221	34	226	35	232	36	
24	237	37	243	38	249	39	255	40	
27	261	41	267	42	274	43	280	44	
30	287	45	294	46	301	47	309	48	
33	316	49	324	50	332	51	340	52	
36	348	53	357	54	365	55	374	56	
39	383	57	392	58	402	59	412	60	
43	422	61	432	62	442	63	453	64	
47	464	65	475	66	487	67	499	68	
51	511	69	523	70	536	71	549	72	
56	562	73	576	74	590	75	604	76	
62	619	77	634	78	649	79	665	80	
68	681	81	698	82	715	83	732	84	
75	750	85	768	86	787	87	806	88	
82	825	89	845	90	866	91	887	92	
91	909	93	931	94	953	95	976	96	

MULTIPLIER CODE

Code	A	B, b	C	D, d	E	F	G	H	X	Y	Z
Multiplier	10 ⁰	10 ¹	10 ²	10 ³	10 ⁴	10 ⁵	10 ⁶	10 ⁷	10 ⁻¹	10 ⁻²	10 ⁻³

MARKING IDENTIFIERS

0603 Size	0805, 1206 and 2512 Size
<p>3 Digit Marking System: 2 digit value code + 1 digit multiplier code</p> <div style="text-align: center;"> </div> <p>E24 0603 Multiplier Code: 10e multiplier E96 0603 Multiplier Code: Per table</p> <p>0603 Marking Examples: 101 = 100 Ω (E24) 13C = 13.3 KΩ (E96) 68B = 4.99 KΩ (E96) 103 = 10 KΩ (E24)</p>	<p>4 Digit Marking System: 3 digit value code + 1 digit multiplier code where "R" denotes a decimal</p> <div style="text-align: center;"> </div> <p>Value Multiplier Code: 10e multiplier</p> <p>Marking Examples: 10R0 = 10 Ω 1332 = 13.3 KΩ 4992 = 49.9 KΩ 1003 = 100 KΩ</p>

NTRN Series

Aluminum Nitride High Precision Thin Film Chip Resistor



TAPING SPECIFICATIONS

Type	EIA Size	A	B	C	W	T	Paper Tape (EA)	Plastic Tape (EA)
NTRN06	0603	1.78 ±1.0	60.0±1.0	13.5 ±0.7	9.5 ± 1.0	11.5 ±1.0	5,000	-
NTRN10	0805						5,000	-
NTRN12	1206						5,000	-
NTRN25	2512				13.5 ± 1.0	15.5 ± 1.0	-	4,000

REEL DIMENSIONS (mm)

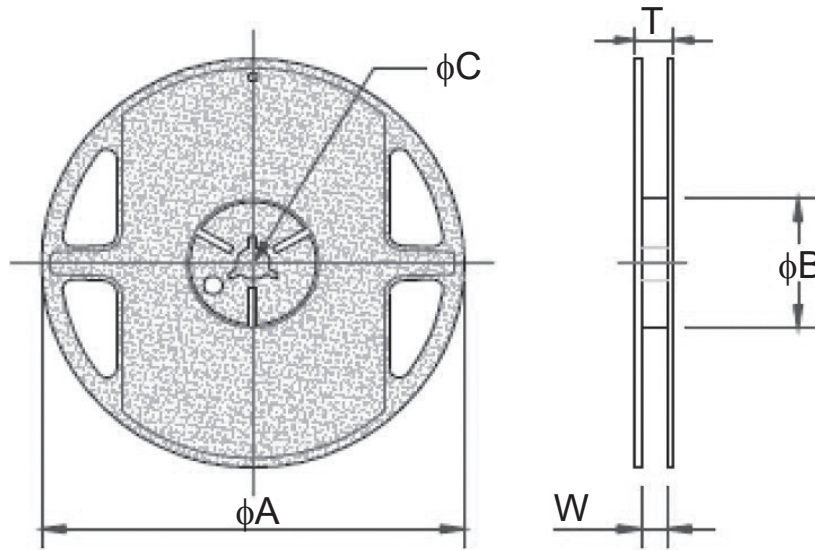

PAPER TAPE DIMENSIONS (mm)

Type	EIA Size	A	B	D	E	F	P ₀	P ₁	P ₂	W	T
NTRN06	0603	1.10 ± 0.05	1.90 ± 0.05	1.55 ± 0.05	1.75 ± 0.05	3.5 ± 0.05	4.00 ± 0.10	4.00 ± 0.10	2.00 ± 0.05	8.00 ± 0.10	0.60 ± 0.03
NTRN10	0805	1.60 ± 0.05	2.37 ± 0.05	1.55 ± 0.05	1.75 ± 0.05	3.5 ± 0.05	4.00 ± 0.10	4.00 ± 0.10	2.00 ± 0.05	8.00 ± 0.10	0.75 ± 0.05
NTRN12	1206	2.00 ± 0.05	3.55 ± 0.05	1.55 ± 0.05	1.75 ± 0.05	3.5 ± 0.05	4.00 ± 0.10	4.00 ± 0.10	2.00 ± 0.05	8.00 ± 0.10	0.75 ± 0.05

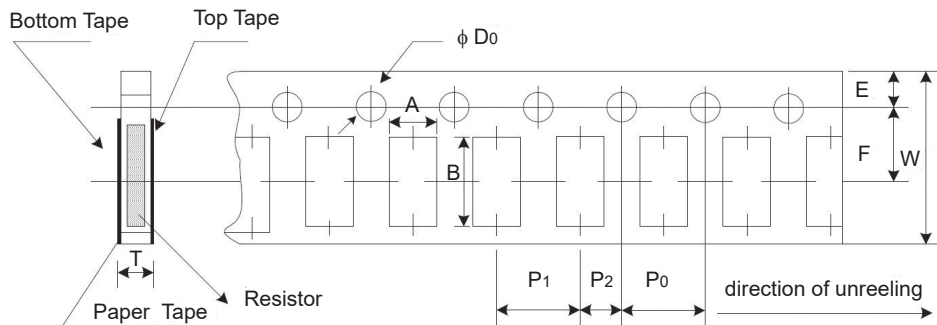

Performance Passives By Design

NTRN Series

Aluminum Nitride High Precision Thin Film Chip Resistor



EMBOSSED PLASTIC CARRIER DIMENSIONS (mm)

Type	EIA Size	A	B	D	E	F	P ₀	P ₁	P ₂	W	T
NTRN25	2512	3.40 ± 0.10	6.65 ± 0.10	1.50 ± 0.10	1.75 ± 0.10	5.5 ± 0.05	4.00 ± 0.10	4.00 ± 0.10	2.00 ± 0.05	12.0 ± 0.10	1.00 ± 0.20

