

FEATURES

- -55°C TO +125°C OPERATING RANGE
- **MEETS THE REQUIREMENTS OF AEC-Q200***
- HIGH RIPPLE CURRENT RATING AT HIGH TEMPERATURE
- EXTENDED LIFETIME: 4000 HOURS @ +125°C
- 8x10.5mm, 10x10.5mm & 10x12.5mm SIZES
- 'W' WIDE TERMINAL OPTION FOR HIGH VIBRATION APPLICATIONS

*Contact NIC for supporting test data

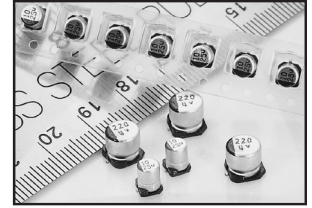

CHARACTERISTICS

Rated Voltage Range	25 ~ 35VDC		
Rated Capacitance Range	150 ~ 470μF		
Operating Temp. Range	-55 ~ +125°C		
Capacitance Tolerance	±20% (M)		
Max. Leakage Current After 2 Minutes @ 20°C	0.01CV		
Working Voltage & Surge Voltage Ratings	W.V. (Vdc)	25	35
	S.V. (Vdc)	32	44
Tan δ @ 120Hz/20°C		0.14	0.12
Temperature Stability Impedance Ratio @ 120Hz	Z -55°C/Z +20°C	1.0 ~ 2.5	
	Z +125°C/Z +20°C	0.6 ~ 1.0	
Load Life Test at W.V. @ 125°C All Case Sizes: 4,000 Hours	Capacitance Change	Within ±30% of initial measured value	
	ESR, Tan δ	Less than 200% of specified max. value	
	Leakage Current	Less than specified max. value	

STANDARD PRODUCT AND CASE SIZE Dφ xL (mm)

Cap.(μF)	Code	Working Voltage (Vdc)	
		25	35
150	151	-	8x10.5
220	221	8x10.5	-
270	271	-	10x10.5
330	331	10x10.5	10x12.5
470	471	10x12.5	-

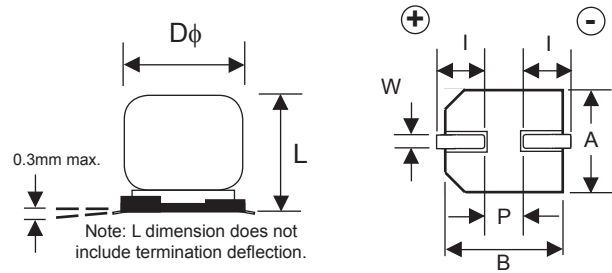

DIMENSIONS (mm)

Case Size	Dφ ±0.5	L max.	A, B ±0.2	l ±0.3	P	W
8x10.5	8.0	10.5	8.3	2.9	(3.2)	0.7 ~ 1.0
10x10.5	10.0	10.5	10.3	3.2	(4.6)	1.0 ~ 1.4
10x12.5	10.0	12.5	10.3	3.2	(4.6)	1.0 ~ 1.4

Part Marking

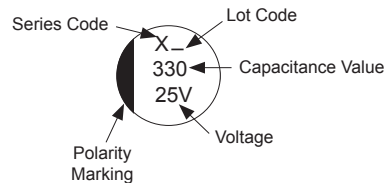

PART NUMBER SYSTEM

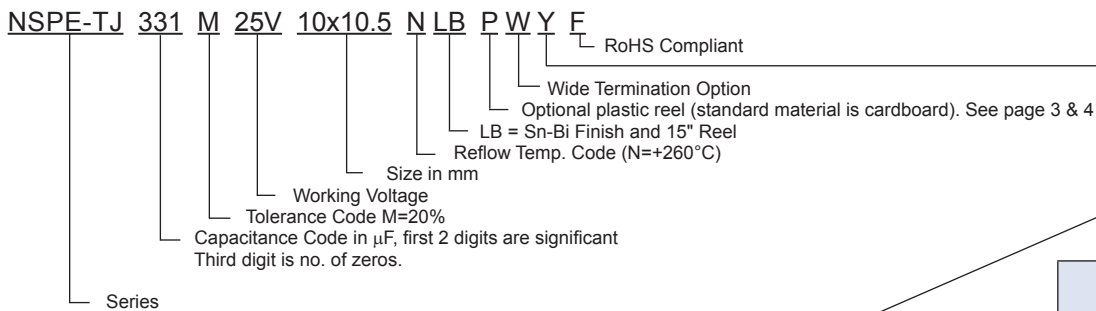

Suitable for automotive equipment, sourced to special production and inspection at TS-16949 certified production site

Termination & Packaging Code
LB = Sn-Bi / 15" reel
Reflow Code
N = +260°C

PRECAUTIONS

Please review the notes on correct use, safety and precautions found at <https://www.niccomp.com/resource/files/aluminum/AlumApplInfoCautions.pdf>
If in doubt or uncertainty, please review your specific application - process details with NIC's technical support personnel: tpmg@niccomp.com



STANDARD VALUES, CASE SIZES & SPECIFICATIONS

Part Number	Cap. (μF)	Working Voltage	Dissipation Factor @120Hz/+20°C	Max. ESR (Ω) AT 100KHz/+20°C	Max. Ripple Current (mA rms) AT 100KHz/+125°C	Load Life Hours @ +125°C
NSPE-TJ221M25V8x10.5NLBYF	220	25V	0.14	0.027	2900	4000
NSPE-TJ331M25V10X10.5NLBYF	330		0.14	0.020	3300	4000
NSPE-TJ471M25V10X12.5NLBYF	470		0.14	0.016	3800	4000
NSPE-TJ151M35V8x10.5NLBYF	150	35V	0.12	0.027	2900	4000
NSPE-TJ271M35V10x10.5NLBYF	270		0.12	0.020	3300	4000
NSPE-TJ331M35V10X12.5NLBYF	330		0.12	0.017	3800	4000

RIPPLE CURRENT FREQUENCY CORRECTION FACTOR

Frequency (Hz)	100 ≤ f <1K	1K ≤ f <10K	10K ≤ f <100K	100K ≤ f <500K
150μF ~ 470μF	0.10	0.35	0.70	1.00

LAND PATTERN DIMENSIONS (mm)

Case Size	a	b	c
8x10.5	2.8	4.1	2.1
10x10.5	4.3	4.4	2.5
10x12.5	4.3	4.4	2.5

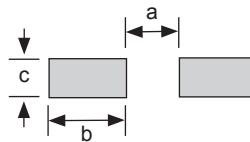

PEAK REFLOW TEMPERATURES AND DURATION

Diameter	Time above +200°C	Time above +217°C	Time above +230°C	Peak Temperature
φ8.0 & φ10mm	Within 70 sec.	Within 40 sec.	Within 30 sec.	+260°C

Capacitors can withstand one reflow passes under the specified conditions.

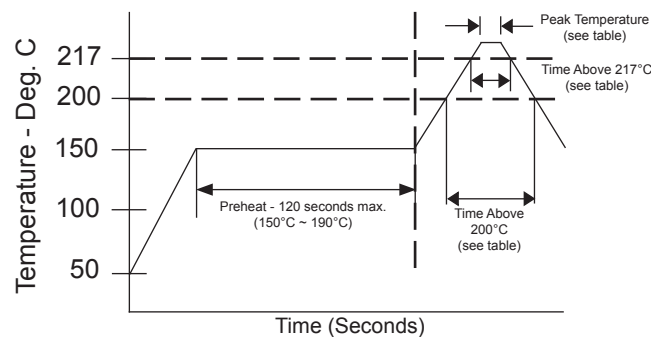

W (WIDE TERMINATIONS) COMPONENT DIM. (mm)

Case Size	Dφ ±0.5	L	A, B ±0.2	C ±0.2	P	W	R	T
8x10.5	8.0	10.7 ± 0.5	8.3	9.0	(3.2)	0.7 ~ 1.0	(0.7)	(1.3)
10x10.5	10.0	10.7 ± 0.5	10.3	11.0	(4.6)	1.0 ~ 1.4	(0.7)	(1.3)
10x12.5	10.0	12.5 ± 1.0	10.3	11.0	(4.6)	1.0 ~ 1.4	(0.7)	(1.3)

W (WIDE TERMINATIONS) LAND PATTERN DIM. (mm)

Case Size	a	b	c
8x10.5	2.5	4.5	4.7
10x10.5	3.8	4.8	4.7
10x12.5	3.8	4.8	4.7

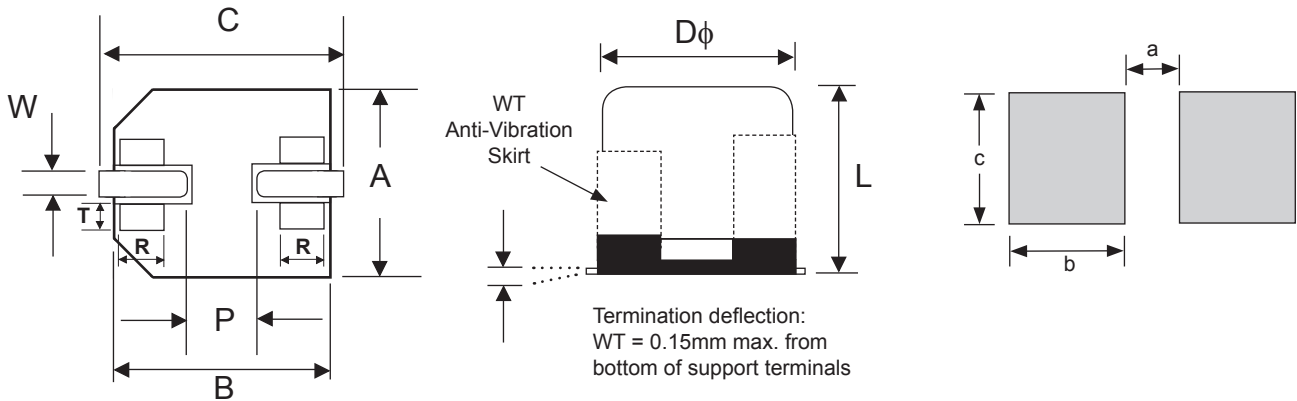

W (Wide Terminations) Anti-Vibration Test	
Test Method	Direction: X, Y, Z axis Frequency & Duration: 5 to 2000Hz reciprocation for 20 minutes, 2 hours total in each direction Peak to Peak Amplitude: 5mm Peak Acceleration: 30G Sweep Type: Log Thickness of Solder Paste: 0.20mm ± 0.03mm
Capacitance	During test measured value to be stabilized
Appearance	No remarkable abnormality

CARRIER TAPE

Case Size	A ±0.2	B ±0.2	C ±0.3	D ±0.1	P ±0.1	T ±0.2	t max.
8x10.5	8.7	8.7	24.0	11.5	16.0	11.1	0.6
10x10.5	10.7	10.7	24.0	11.5	16.0	11.2	0.6
10x12.5	10.7	10.7	24.0	11.5	16.0	13.3	0.6

LB 380mm (15") CARDBOARD REEL

(See page 4 for plastic reel dimensions)

Case Size	W +3/-1	Qty per Reel
		15" (380mm)
8x10.5	26	500
10x10.5	26	500
10x12.5	26	400

TAPING SPECIFICATIONS (mm)

- Both Leader and Trailer tape: Minimum 10 empty carrier tape pockets.
- Leader tape: Approximately 20cm of cover tape at leader.
- Connection: Maximum 3 connections (slices) per reel.

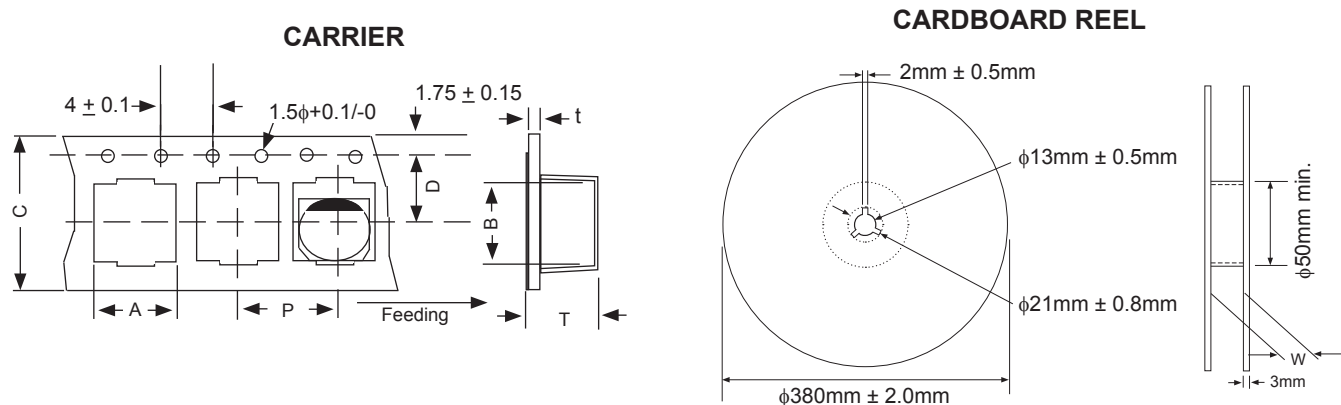

Review & Compare Reflow Soldering Heat Limits
V-chip SMT Aluminum Electrolytic Capacitors
www.niccomp.com/RSL



Optional V-Chip 15" (380mm) Plastic Reels (LBP suffix)

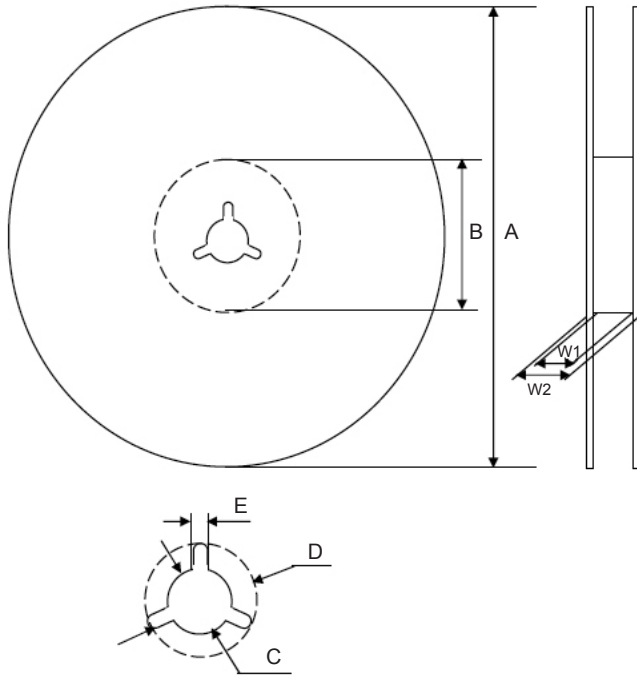

Dimensions (mm)

Case Size	Tape Width	W1	W2
8x10.5, 10x10.5, 10x12.5	24.0	24.5 ~ 26.0	27.5 ~ 32.0

Case Size	Tape Width	A	B	C	D	E
8x10.5, 10x10.5, 10x12.5	24.0	$\phi 380 \pm 2$	$\phi 80 \sim 105$	$\phi 13 \pm 0.5$	$\phi 21 \pm 1.0$	2.0 ± 0.5

Color
Black or Blue

Case Size	Qty per Reel 15" (380mm)
8x10.5	500
10x10.5	500
10x12.5	400