

NPMS Series

Miniaturized Molded Chip Power Inductors



FEATURES

- 0605, 0603, 0805, 0806 AND 1008 CASE SIZES
- METAL MATERIAL FOR LARGE CURRENT AND LOW LOSS
- VINYL THERMAL SPRAY, BETTER SURFACE COMPACTNESS
- CLOSED MAGNETIC CIRCUIT DESIGN REDUCES LEAKAGE

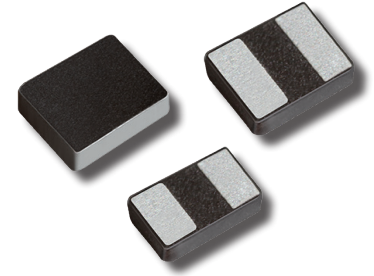

SPECIFICATIONS

Specifications	Case Size				
	0605	0603	0805	0806	1008
Inductance Range	0.24uH ~ 0.47uH	0.47uH~ 2.2uH	0.11uH ~ 2.2uH	0.24uH ~ 4.7uH	0.24uH ~ 10uH
Inductance Tolerance	±20% (M), ±30% (N)				
Operating Temperature Range	-40°C ~ +125°C (including self-heating)				
Self Resonant Frequency, DC Resistance, Rated DC Current and Inductance Tolerance	See Standard Values and Specifications Table				

Note: Extended values, tolerances, and enhanced versions are available please contact NIC for more details.

DIMENSIONS (mm) & COMPOSITION

Case Size	L	W	H*	P
NPMS0605	1.4 ± 0.20	1.20 ± 0.20	0.65 Max	0.4 ± 0.15
			0.8 Max	
NPMS0603	1.6 ± 0.20	0.8 ± 0.20	0.8 Max	0.4 ± 0.20
NPMS0805	2.0 ± 0.20	1.20 ± 0.20	0.65 Max	0.6 ± 0.20
			0.8 Max	
			1.0 Max	
NPMS0806	2.0 ± 0.20	1.60 ± 0.20	0.8 Max	0.6 ± 0.20
			1.0 Max	
NPMS1008	2.5 ± 0.20	2.0 ± 0.20	0.8 Max	0.8 ± 0.20
			1.0 Max	

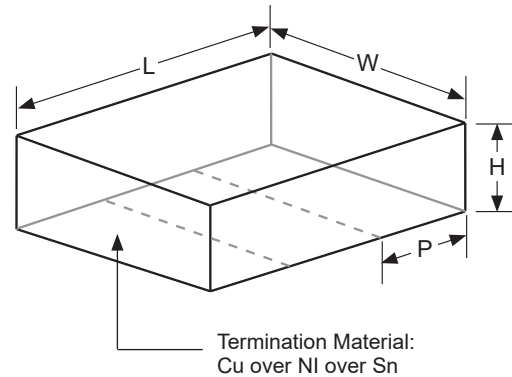

*See specifications tables for individual part thickness

PART NUMBER SYSTEM

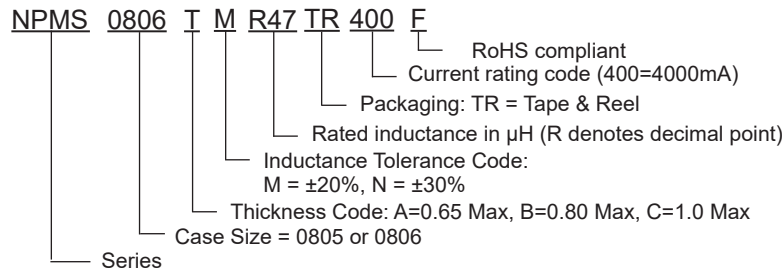

NPMS Series

Miniaturized Molded Chip Power Inductors



NPMS0605 SERIES (0605 Size Code, 1.4 x 1.2 mm)

NIC P/N	'L' Inductance (uH)	Tolerance	"L" Test Frequency (MHz)	SRF MHz (min.)	DCR (ohms)	Isat Max. (A)	Irms Max. (A)	Thickness (mm)
NPMS0605A_R33TR350F	0.33	±20% (M), ±30% (N)	1	120	0.028	5.4	3.5	0.65 Max
NPMS0605A_R47TR290F	0.47	±20% (M), ±30% (N)	1	115	0.036	3	2.9	
NPMS0605B_R24TR490F	0.24	±20% (M), ±30% (N)	1	135	0.02	6.5	4.9	0.8 Max
NPMS0605B_R33TR380F	0.33	±20% (M), ±30% (N)	1	130	0.023	5.2	3.8	
NPMS0605B_R47TR320F	0.47	±20% (M), ±30% (N)	1	110	0.028	4	3.2	

NPMS0603 SERIES (0603 Size Code, 1.6 x 0.8 mm)

NIC P/N	'L' Inductance (uH)	Tolerance	"L" Test Frequency (MHz)	SRF MHz (min.)	DCR (ohms)	Isat Max. (A)	Irms Max. (A)	Thickness (mm)
NPMS0603B_R47TR300F	0.47	±20% (M), ±30% (N)	1	100	0.038	3.3	3.0	0.8 Max
NPMS0603B_1R0TR180F	1.0	±20% (M), ±30% (N)	1	60	0.095	2.1	1.8	
NPMS0603B_2R2TR100F	2.2	±20% (M), ±30% (N)	1	40	0.240	1.2	1.0	

NPMS0805 SERIES (0805 Size Code, 2.0 x 1.2 mm)

NIC P/N	'L' Inductance (uH)	Tolerance	"L" Test Frequency (MHz)	SRF MHz (min.)	DCR (ohms)	Isat Max. (A)	Irms Max. (A)	Thickness (mm)
NPMS0805A_R47TR400F	0.47	±20% (M), ±30% (N)	1	96	0.032	4.5	4.0	0.65 Max
NPMS0805A_1R0TR240F	1.0	±20% (M), ±30% (N)	1	53	0.078	2.5	2.4	
NPMS0805A_2R2TR150F	2.2	±20% (M), ±30% (N)	1	50	0.173	1.6	1.5	
NPMS0805B_R11TR560F	0.11	±20% (M), ±30% (N)	1	185	0.01	10	5.6	0.8 Max
NPMS0805B_R24TR540F	0.24	±20% (M), ±30% (N)	1	130	0.016	6.5	5.4	
NPMS0805B_R33TR400F	0.33	±20% (M), ±30% (N)	1	125	0.023	5.6	4.0	
NPMS0805B_R47TR370F	0.47	±20% (M), ±30% (N)	1	96	0.037	5.5	3.7	
NPMS0805B_R47TR400F	0.47	±20% (M), ±30% (N)	1	96	0.022	4.5	4.0	
NPMS0805B_1R0TR200F	1.0	±20% (M), ±30% (N)	1	74	0.092	2.8	2.0	
NPMS0805B_1R0TR320F	1.0	±20% (M), ±30% (N)	1	60	0.046	3.3	3.2	
NPMS0805B_2R2TR110F	2.2	±20% (M), ±30% (N)	1	45	0.216	2.2	1.1	
NPMS0805B_2R2TR180F	2.2	±20% (M), ±30% (N)	1	42	0.12	1.9	1.8	
NPMS0805C_R11TR640F	0.11	±20% (M), ±30% (N)	1	264	0.008	13	6.4	
NPMS0805C_R24TR450F	0.24	±20% (M), ±30% (N)	1	136	0.019	6.2	4.5	1.0 Max
NPMS0805C_R24TR500F	0.24	±20% (M), ±30% (N)	1	136	0.012	6.8	5.0	
NPMS0805C_R47TR480F	0.47	±20% (M), ±30% (N)	1	96	0.021	5.1	4.8	
NPMS0805C_1R0TR310F	1.0	±20% (M), ±30% (N)	1	56	0.046	3.6	3.1	
NPMS0805C_2R2TR190F	2.2	±20% (M), ±30% (N)	1	36	0.1	2.1	1.9	

Note: Extended values, tolerances, and enhanced versions are available please contact NIC for more details.

Performance Passives By Design

NIC Components Corp.
100 Baylis Road. Melville, NY 11747

Page 2

www.niccomp.com

Last Updated 11-11-2022. Specification subject to change without notice. Please check web site for latest information.

NPMS Series

Miniaturized Molded Chip Power Inductors



NPMS0806 SERIES (0806 Size Code, 2.0 x 1.6 mm)

NIC P/N	'L' Inductance (uH)	Tolerance	"L" Test Frequency (MHz)	SRF MHz (min.)	DCR (ohms)	Isat Max. (A)	Irms Max. (A)	Thickness (mm)
NPMS0806B_R24TR440F	0.24	±20% (M), ±30% (N)	1	120	0.018	5.7	4.4	0.8 Max
NPMS0806B_R47TR360F	0.47	±20% (M), ±30% (N)	1	104	0.021	5.0	3.6	
NPMS0806B_1R0TR270F	1.0	±20% (M), ±30% (N)	1	62	0.059	3.3	2.7	
NPMS0806B_1R0TR370F	1.0	±20% (M), ±30% (N)	1	57	0.045	4.1	3.7	
NPMS0806B_2R2TR180F	2.2	±20% (M), ±30% (N)	1	40	0.134	2.3	1.8	
NPMS0806C_R24TR500F	0.24	±20% (M), ±30% (N)	1	142	0.014	7.0	5.0	1.0 Max
NPMS0806C_R33TR480F	0.33	±20% (M), ±30% (N)	1	110	0.018	6.8	4.8	
NPMS0806C_R47TR400F	0.47	±20% (M), ±30% (N)	1	98	0.026	6.0	4.0	
NPMS0806C_R47TR480F	0.47	±20% (M), ±30% (N)	1	72	0.018	5.6	4.8	
NPMS0806C_1R0TR350F	0.68	±20% (M), ±30% (N)	1	68	0.03	4.8	3.5	
NPMS0806C_1R0TR340F	1.0	±20% (M), ±30% (N)	1	46	0.042	4.6	3.4	
NPMS0806C_1R5TR280F	1.5	±20% (M), ±30% (N)	1	40	0.064	3.2	2.8	
NPMS0806C_2R2TR210F	2.2	±20% (M), ±30% (N)	1	40	0.123	3.8	2.1	
NPMS0806C_4R7TR130F	4.7	±20% (M), ±30% (N)	1	26	0.213	1.6	1.3	

NPMS1008 SERIES (1008 Size Code, 2.5 x 2.0 mm)

NIC P/N	'L' Inductance (uH)	Tolerance	"L" Test Frequency (MHz)	SRF MHz (min.)	DCR (ohms)	Isat Max. (A)	Irms Max. (A)	Thickness (mm)
NPMS1008B_1R0TR320F	1.0	±20% (M), ±30% (N)	1	55	0.046	3.5	3.2	0.8 Max
NPMS1008B_4R7TR165F	4.7	±20% (M), ±30% (N)	1	20	0.165	1.75	1.65	
NPMS1008B_100TR095F	10	±20% (M), ±30% (N)	1	14	0.507	1.2	0.95	
NPMS1008C_R33TR500F	0.33	±20% (M), ±30% (N)	1	95	0.013	7.5	5.0	1.0 Max
NPMS1008C_R47TR470F	0.47	±20% (M), ±30% (N)	1	81	0.016	6.0	4.7	
NPMS1008C_R47TR570F	0.47	±20% (M), ±30% (N)	1	61	0.016	8.0	5.7	
NPMS1008C_R68TR450F	0.68	±20% (M), ±30% (N)	1	63	0.024	5.8	4.5	
NPMS1008C_1R0TR340F	1.0	±20% (M), ±30% (N)	1	53	0.038	4.5	3.4	
NPMS1008C_1R0TR360F	1.0	±20% (M), ±30% (N)	1	55	0.032	5.8	3.6	
NPMS1008C_1R0TR450F	1.0	±20% (M), ±30% (N)	1	53	0.027	5.0	4.5	
NPMS1008C_1R5TR360F	1.5	±20% (M), ±30% (N)	1	35	0.037	3.7	3.6	
NPMS1008C_2R2TR230F	2.2	±20% (M), ±30% (N)	1	27	0.057	3.2	2.3	
NPMS1008C_3R3TR190F	3.3	±20% (M), ±30% (N)	1	22	0.095	2.6	1.9	
NPMS1008C_4R7TR160F	4.7	±20% (M), ±30% (N)	1	19	0.124	1.9	1.6	
NPMS1008C_100TR120F	10	±20% (M), ±30% (N)	1	14	0.36	1.5	1.2	

ENVIRONMENTAL CHARACTERISTICS

Test	Test Method & Condition
Resistance to Soldering Heat	Solder temperature: 260±5°C, residence time:10±1s, Depth: the tin surface is 1.5mm from the element body, Speed:25mm/s±6mm/s; Solder: Sn/3.0Ag/0.5Cu. Place at room temperature for at least 24 ± 2 hours before measurements.
High Frequency Vibration	Reflow 3 times, soldered on board, 20Hz~2000Hz~20Hz, 1.5mm, peak acceleration 20G, 4mins for 1 cycle, 4 cycles in each X,Y,Z directions(16min), total of 12 cycles(48 mins).
Thermal Shock	Reflow 3 times, -40°C/(30±3min)-->+125°C/(30±3min), transforming interval:20s,100cycles.
Humidity	Reflow 3 times,85°C, 85%RH,1000hours. Place at room temperature for at least 24 ± 2 hours before measurements.
Low Temperature Storage	Reflow 3 times,-40±2°C, 1000h, Place at room temperature for at least 24 ±2 hours before measurements.
High Temperature Load Life	Reflow 3 times, 85±2°C,1000(+24) hours,rated current,3.6A

Note: Extended values, tolerances, and enhanced versions are available please contact NIC for more details.

Performance Passives By Design

NIC Components Corp.
100 Baylis Road. Melville, NY 11747

Page 3
www.niccomp.com

NPMS Series

Miniaturized Molded Chip Power Inductors



REFLOW SOLDERING PROFILE

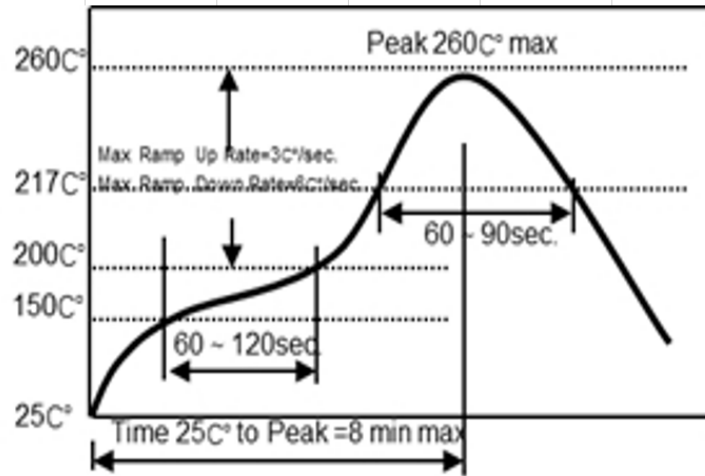

LAND PATTERN DIMENSIONS

Series	A	B	C
NPMS0603	0.7 Typ.	0.6 Typ.	0.8 Typ.
NPMS0605	0.5 Typ.	0.6 Typ.	1.2 Typ.
NPMS0805	0.7 Typ.	0.8 Typ.	1.2 Typ.
NPMS0806	0.7 Typ.	0.8 Typ.	1.6 Typ.
NPMS1008	0.8 Typ.	1.0 Typ.	2.0 Typ.

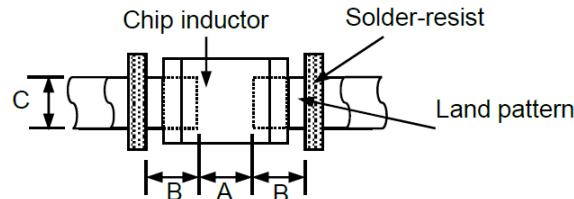

CARRIER DIMENSIONS & REEL QUANTITY (mm)

TYPE	Part Thickness	L	W	a	Carrier Material	Reel Qty
NPMS0605	0.65	1.4 ±0.2	1.2 ±0.2	0.4±0.15	Metal Alloy	3K
	0.8				Metal Alloy	3K
NPMS0603	0.8	1.6 ±0.2	0.8 ±0.2	0.4±0.2	Metal Alloy	3K
					Metal Alloy	3K
NPMS0805	0.8	2.0 ±0.2	1.2 ±0.2	0.6±0.2	Metal Alloy	3K
	1.0				Metal Alloy	3K
NPMS0806	0.8	2.0 ±0.2	1.6 ±0.2	0.6±0.2	Metal Alloy	3K
	1.0				Metal Alloy	3K
NPMS1008	0.8	2.5 ±0.2	2.0 ±0.2	0.8±0.2	Metal Alloy	3K
	1.0				Metal Alloy	3K

NPMS Series

Miniaturized Molded Chip Power Inductors



PAPER CARRIER DIMENSIONS (mm)

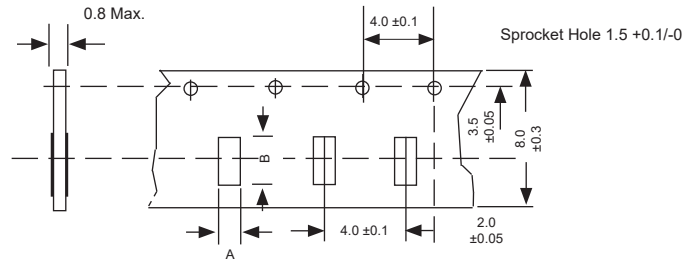

EMBOSSED PLASTIC CARRIER DIMENSIONS (mm)

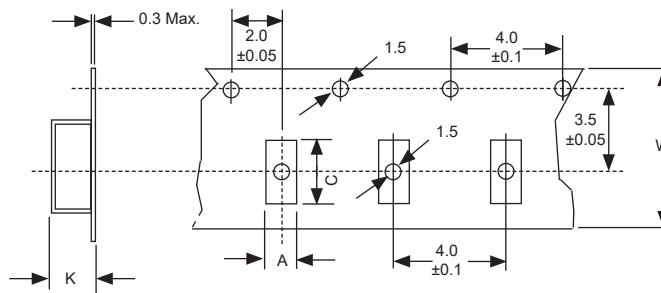

REEL DIMENSIONS (mm)

