

FEATURES

- ULTRA LOW PROFILE (1.2mm MAX. HEIGHT)
- SURFACE MOUNTABLE CONSTRUCTION
- HIGH INDUCTANCE (UP TO 330 μ H)
- TAPED AND REELED FOR AUTOMATIC INSERTION

**RoHS
Compliant**
includes all homogeneous materials



*See Part Number System for Details

CHARACTERISTICS

Case Size	NPI17L
Inductance Range	1.2 μ H ~ 330 μ H
Temperature Range	-20°C ~ +105°C
Temperature Rise at Irms	40°C max.
Inductance Change at Isat	-30% typical
Inductance Tolerance	20% (M)
Resistance to Solder Heat	260°C for 5 seconds

PART NUMBER SYSTEM

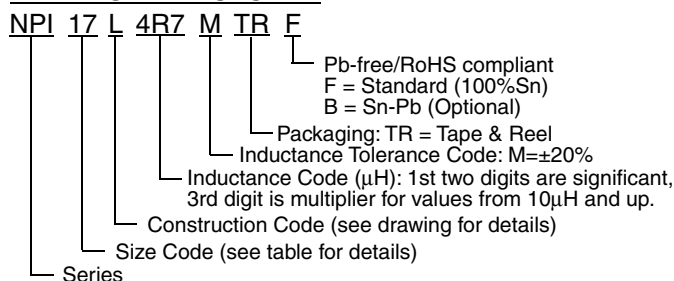

Part Number	STANDARD VALUES - CASE SIZE 17 (5.5 x 6.6 x 1.2mm)			
	Inductance Value (μ H)	DC Resistance (Ω)	DC Current Isat (Irms)	Test Frequency
NPI17L1R2MTRF	1.2 μ H \pm 20%	0.12	2.10	100KHz
NPI17L1R5MTRF	1.5 μ H \pm 20%	0.15	1.90	
NPI17L2R2MTRF	2.2 μ H \pm 20%	0.20	1.60	
NPI17L3R3MTRF	3.3 μ H \pm 20%	0.25	1.30	
NPI17L4R7MTRF	4.7 μ H \pm 20%	0.28	1.10	
NPI17L6R8MTRF	6.8 μ H \pm 20%	0.32	0.90	
NPI17L100MTRF	10 μ H \pm 20%	0.41	0.80	
NPI17L150MTRF	15 μ H \pm 20%	0.60	0.65	
NPI17L220MTRF	22 μ H \pm 20%	0.85	0.50	
NPI17L330MTRF	33 μ H \pm 20%	1.30	0.40	
NPI17L470MTRF	47 μ H \pm 20%	1.80	0.35	
NPI17L680MTRF	68 μ H \pm 20%	2.50	0.30	
NPI17L101MTRF	100 μ H \pm 20%	3.50	0.25	
NPI17L151MTRF	150 μ H \pm 20%	5.00	0.18	
NPI17L221MTRF	220 μ H \pm 20%	8.00	0.16	
NPI17L331MTRF	330 μ H \pm 20%	15.0	0.13	

Maximum +40°C temperature rise at Irms. Typical -30% inductance change at Isat.

PART AND LAND PATTERN DIMENSIONS

Series	A	B	C	D (ref)	E (ref)	I (ref)	G (ref)	H (ref)
NPI17L	5.5 Max	6.60 Max	1.20 Max	0.75	2.50	1.1	4.7	2.5

NPI17L

LAND PATTERN

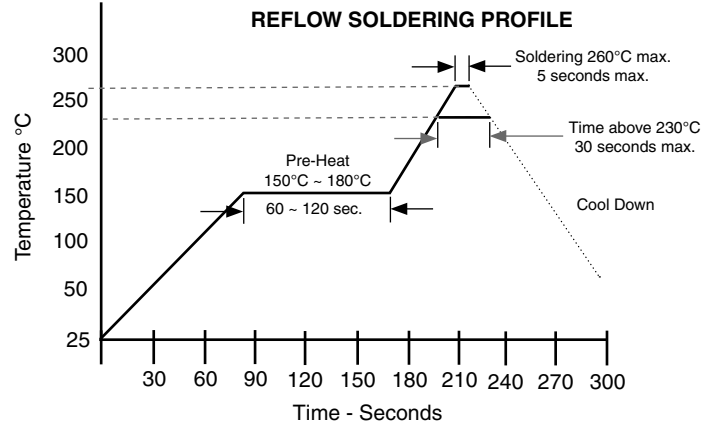
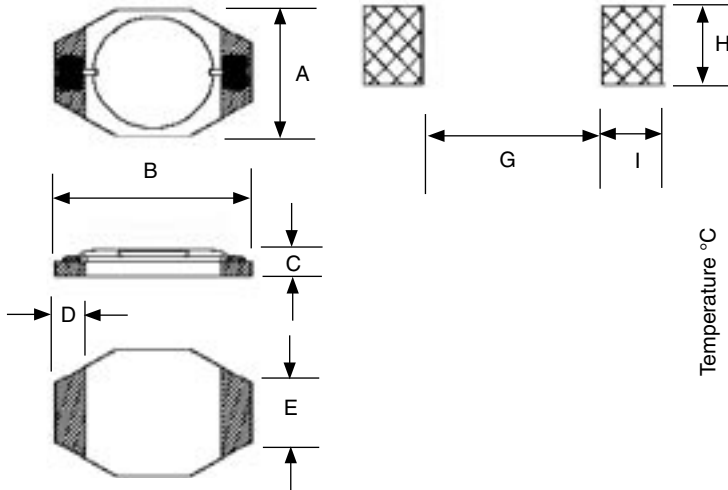

Case Size	TAPING DIMENSIONS (mm)					
	Ao	Bo	Co	Ko	W	Po
NPI17L	5.8	6.8	7.5	1.4	16	8.0

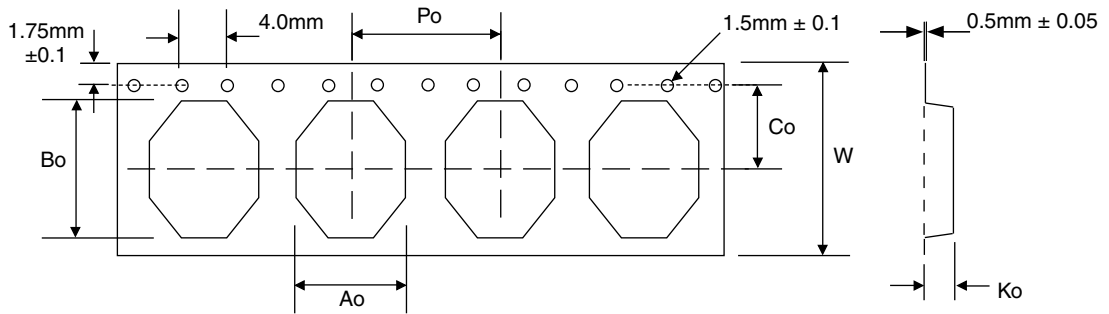

Tape Width	REEL DIMENSIONS (mm) & QUANTITY				
	A(mm)	B(mm)	C(mm)	D(mm)	Qty/Reel
16mm	12.5±0.1	50±1	13±0.2	178	1,000

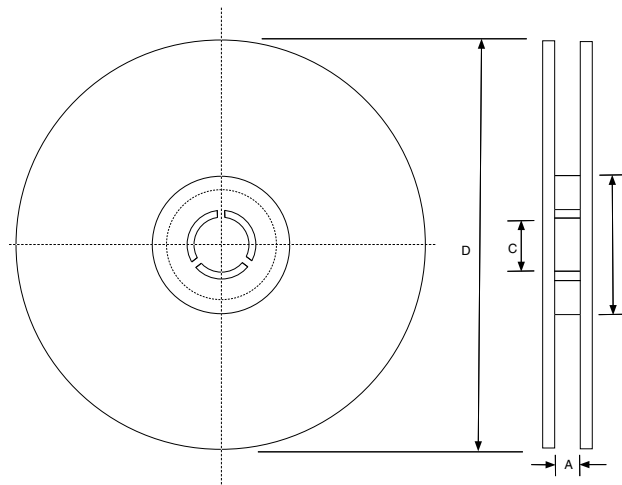

Isat and Irms

NPI & NPIS Series

Isat (Saturation Current) - is the current required to **decrease the inductance** value by the specified maximum amount (given as a percentage of the nominal inductance value).

Irms - is the current required to **increase the temperature** of the part a maximum specified amount (given as a temperature rise in °C).

In some instances Isat and Irms are shown separately with a maximum decrease in inductance specified at one current rating (Isat) and a maximum temperature rise specified at another current rating (Irms). In other cases one current value is given for both (specified as Idc) and represents the current at which a specified maximum inductance decrease and a maximum specified temperature rise can occur. The graph below illustrates change in inductance and temperature as current increases.

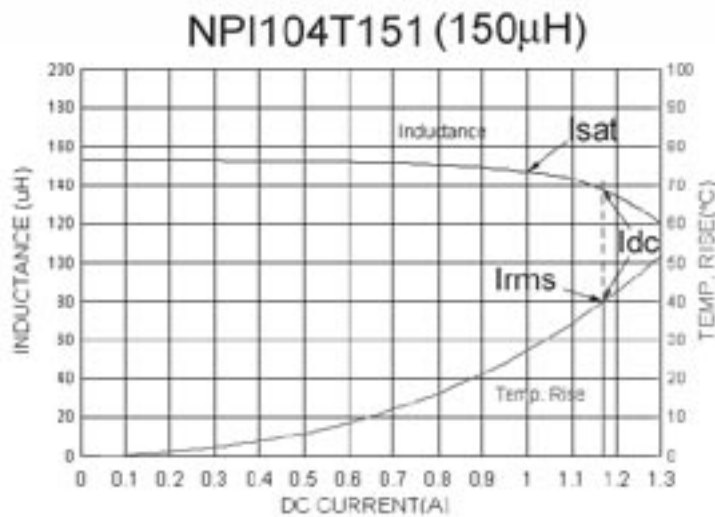

Based on the above graph Isat and Irms could be expressed as follows:

1. Isat and Irms can be shown as separate current values. The Isat current is a value of current that could potentially produce a specified maximum inductance change [-5%, -10%, -20%, etc. of the nominal value]. In this case a 1.0A current has produced a -5% inductance change so 1.0A could be specified as the inductor's Isat current rating. The Irms could be expressed as the current that produces a +40°C temperature rise which in this case is about 1.18A.
2. Both Isat and Irms can be expressed using one current value (Idc). In the above graph 1.18A could be specified as the Idc for the part noting that at 1.18A a potential +40°C temperature rise (equivalent to Irms) and a -10% change in inductance (equivalent to Isat) could occur.